

Fig. 122 / 229 PN40

Robinet à soupape

- Acier
- A soufflet
- Contacts inox
- Pour eau, air, vapeur et tout autre fluide non agressif et non toxique

Globe valve

- Cast steel
- With bellow
- Stainless steel seats
- For water, steam, thermic fluid and any other non aggressive and non toxic medium

Absperventil

- Stahlguss
- Mit Faltenbalg
- Niro dichtend
- Für Wasser, Dampf und anderen nicht aggressive Flüssigkeiten

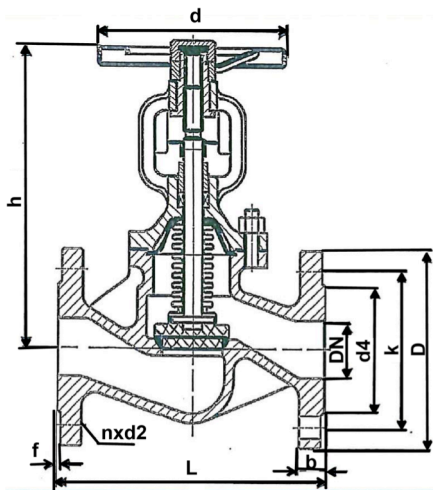

Dimensions entre brides selon DIN EN 558-1, série 1

Face to face dimensions according to DIN EN 558-1, series 1

Baulänge nach DIN EN 558-1, Grundreihe 1

DN	L	D	k	d4	d	h	n	d2	b	f	Nbre de tours Nr of turn	Poids
												Weight
												Gewicht
												kg
15	130	95	65	45	120	208	4	14	16	2	3,5	4,5
20	150	105	75	58	140	121	4	14	18	2	3,0	4,9
25	160	115	85	68	140	217	4	14	18	2	4,0	5,8
32	180	140	100	78	140	215	4	18	18	2	4,0	7,4
40	200	150	110	88	160	235	4	18	18	3	4,0	9,4
50	230	165	125	102	160	235	4	18	20	3	8,0	12,2
65	290	185	145	122	180	252	8	18	22	3	5,0	17,3
80	310	200	160	138	200	270	8	18	24	3	5,0	23,4
100	350	235	190	162	250	347	8	22	24	3	6,0	40,4
125	400	270	220	188	250	380	8	26	26	3	6,5	58,0
150	480	300	250	218	360	420	8	26	28	3	7	83,8
200	600	375	320	285	450	570	12	30	34	3	9	133,0
250	730	450	385	345	500	725	12	33	38	3	-	288,0
300	850	515	450	410	500	788	16	33	42	3	-	391,0

Conditions de service / Working conditions / Betriebsdruck und Temperatur

Température (°C)	-10	20	200	300	400
Pression / Pressure / Druck (bar)	40	40	35	28	21

Matières / Materials / Material

- Corps :** GP240GH+N
- Chapeau :** GP240GH+N
- Volant :** EN-GJS-400
- Clapet :** X20 CR 13
- Tige :** X20 CR 13
- Soufflet :** Inox (X5 CR NI 18-10)
- Etanchéité de tige :** Graphite
- Etanchéité des sièges :** X20 CR 13

- Body :** GP240GH+N
- Bonnet :** GP240GH+N
- Handwheel :** EN-GJS-400
- Disc :** X20 CR 13
- Stem :** X20 CR 13
- Bellow :** X5 CR NI 18-10
- Gland packing :** Graphite
- Seats :** X20 CR 13

- Gehäuse :** GP240GH+N
- Deckel :** GP240GH+N
- Handrad :** EN-GJS-400
- Kegel :** X20 CR 13
- Spindel :** X20 CR 13
- Faltenbalg :** X5 CR NI 18-10
- Packung :** Graphit
- Sitzring :** X20 CR 13

04-2013



ROBINETTERIE INDUSTRIELLE
30 rue Henri Durre - 59590 RAISMES
Tél. 33 (0)3 27 36 70 12 - Fax 33 (0)3 27 36 75 20

CE PED 97/23



www.stemat-jansen.fr

Document non contractuel