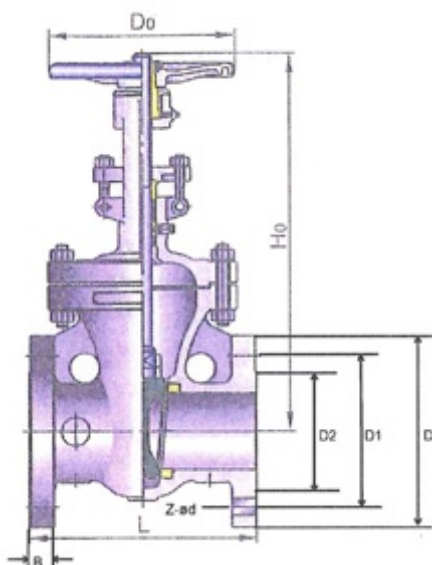

**Fig. 035 / 79 PN63**



**Vanne à passage direct**

- Corps acier
- Tige montante
- Contacts Inox
- Pour les eaux, vapeur, fluide thermique, agents non agressifs

**Gate valve**

- Cast steel
- Outside stem
- Seats in Stainless steel
- For non aggressive medium, water, steam

**Keilrundschieber**

- Stahlguss
- Aussen Spindel
- Niro dichtend
- Für nicht aggressive Flüssigkeiten, Gas, Dampf

**Dimensions entre brides selon DIN EN 558 – 1, série 26**

**Face to face dimensions according to DIN EN 558 – 1, series 26**

**Baulänge nach DIN EN 558 – 1, Grundreihe 26**

DN	L	D	D <sub>2</sub>	D <sub>1</sub>	D <sub>0</sub>	F	B	Z-Ød	H <sub>0</sub>	Poids
										Weight
										Gewicht
mm										kg
50	250	180	102	135	200	3	26	4-Ø22	470	39
65	290	205	122	160	250	3	26	8-Ø22	520	43
80	310	215	138	170	300	3	28	8-Ø22	570	60
100	350	250	162	200	300	3	30	8-Ø26	700	89
125	400	295	188	240	350	3	34	8-Ø30	780	140
150	450	345	218	280	350	3	36	8-Ø33	850	207
200	550	415	270	345	400	3	42	12-Ø36	1035	325
250	650	470	325	400	560	3	46	12-Ø36	1050	467
300	750	530	375	460	640	4	52	16-Ø36	1470	590

**Conditions de service**

**Working conditions**

**Betriebsdruck und Temperatur**

Température (°C)	-10	0	100	150	200	300	400
Pression / Pressure / Druck (bar)	63	63	63	63	54	36	33

**Matières / Materials / Material**

- Corps** : GSC25N/GP240GH/1.0619N
- Chapeau** : GSC25N/GP240GH/1.0619N
- Opércule** : GSC25N/GP240GH/1.0619N
- Volant** : EN GJS-400
- Tige** : X 20 CR 13
- Étanchéité de tige** : Graphite
- Sièges** : X 20 CR 13
- Étanchéité corps/chapeau** : Metal-graphite

- Body** : GSC25N/GP240GH/1.0619N
- Bonnet** : GSC25N/GP240GH/1.0619N
- Wedge** : GSC25N/GP240GH/1.0619N
- Handwheel** : EN GJS-400
- Stem** : X 20 CR 13
- Gland packing** : Graphite
- Seats** : X 20 CR 13
- Gasket body/bonnet** : Metal-graphite

- Gehäuse** : GSC25N/GP240GH/1.0619N
- Deckel** : GSC25N/GP240GH/1.0619N
- Keil** : GSC25N/GP240GH/1.0619N
- Handrad** : EN GJS-400
- Spindel** : X20 CR13
- Packung** : Graphit
- Sitzring** : X20 CR13
- Dichtung** : Metal-graphit

04-2013



ROBINETTERIE INDUSTRIELLE  
30 rue Henri Durre - 59590 RAISMES  
Tél. 33 (0)3 27 36 70 12 - Fax 33 (0)3 27 36 75 20

CE PED 97/23



www.stemat-jansen.fr

Document non contractuel